

## HAT TurboBattledore

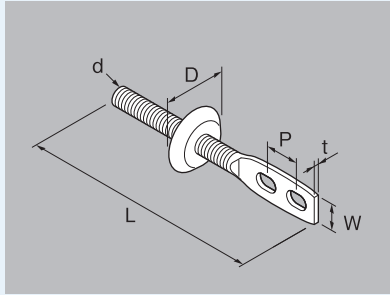

- This product is a mounting bracket for the vertical band.
- Production at the designated length is also accepted.
- It is also possible to produce types without washers.
- The number in the parentheses fo quantity indicates the quantity in the pouch.
- When using hot-dip galvanized products, please use an over tapped galvanized anchor etc.

Material	Unichrome (U)	Hot-dip galvanized (Z)	Stainless steel (S)
Model No.	BUS	Z-BUS	S-BUS

Model No.	Screw length	Overall length L	Width W	Sheet Thickness t			Elongated Hole	d	P	D	Quantity	Delivery Date Confirmation										
				U	Z	S						U	Z	S								
HAT30	30	80									—	*	*	*								
HAT50	50	100									400 (25)	*	*	*								
HAT65	65	115									400 (25)	*	*	*								
HAT75	75	125									350 (25)	*	*	*								
HAT100	100	150	17	3.0	3.0	3.0	8.5×13	W3/8	20	38	250 (25)	*	*	*								
HAT125	125	175									200 (25)	*	*	*								
HAT150	150	200									200 (25)	*	*	*								
HAT200	200	250									150 (25)	*	*	*								
HAT250	250	300									125 (25)	*	*	*								
HAT300	300	350									100 (25)	*	*	*								
HATW3*100-3	3/8×100	160																	160	*	*	*
HATW3*150-3	3/8×150	210									18	3.0	3.0	3.0		W3/8			—	*	*	*
HATW3*200-3	3/8×200	260	—	*	*	*																
HATW3*300-3	3/8×300	360	100	*	*	*																
HATW4*100-3	1/2×100	160	20	4.5	4.5	4.5	11×18	W1/2			120	*	*	*								
HATW4*150-3	1/2×150	210									—	*	*	*								
HATW4*200-3	1/2×200	260									—	*	*	*								
HATW4*300-3	1/2×300	360									80	*	*	*								

## BCA Beauty Clamp A

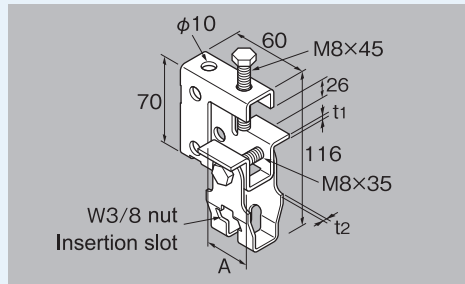

- This product is attach a bolt to the section steel.
- ⚠ Please fix the bolt with double nut.

Allowable static load of each example	A		B		C		D	
	U	S	U	S	U	S	U	S
	1764N	(180kgf)	1617N	(165kgf)	588N	(60kgf)	392N	(40kgf)

Material	Unichrome(U)	Hot-dip galvanized(Z)	Stainless steel(S)
Model No.	BCA	Z-BCA	S-BCA

Model No.	Compliance standard			A	Sheet Thickness t1		Sheet Thickness t2		Quantity	Delivery Date Confirmation		
	Hanging Bolt	Flange thickness	Lip Channel steel		U	S	U	S		U	Z	S
BCA	3/8(M10)	1~25	75×45×15~100×50×20	35	3.0	2.5	2.3	2.0	50	*	*	*

## BCB Beauty Clamp B

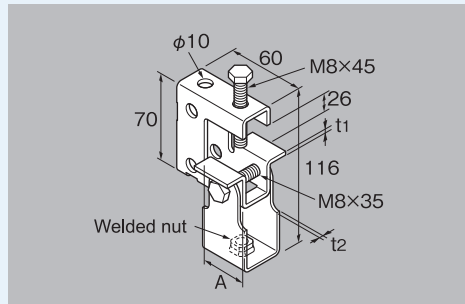
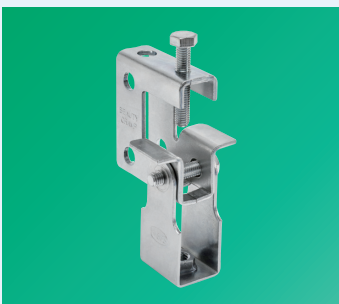

- This product is attach a bolt to the section steel.
- The pendulum has a welded nut.

Allowable static load of each example	A		B		C		D	
	U	S	U	S	U	S	U	S
	1764N	(180kgf)	1617N	(165kgf)	588N	(60kgf)	392N	(40kgf)

Material	Unichrome(U)	Hot-dip galvanized(Z)	Stainless steel(S)
Model No.	BCB	Z-BCB	S-BCB

Model No.	Standard	Compliance standard			A	Sheet Thickness t1		Sheet Thickness t2		Quantity	Delivery Date Confirmation			
		Welded nut	Flange thickness	Lip Channel steel		U	Z	S	U		Z	S		
BCB3	BC-B 3/8	3/8	1~25	75×45×15~100×50×20	35	3.0	3.0	2.5	2.3	2.3	2.0	50	*	*
BCB4	BC-B 1/2	1/2				3.0	3.0	2.5	2.3	2.3	2.0	50	*	*